

CHECK VALVES FOR GENERAL APPLICATIONS

TVR2 of stainless steel

for use with liquid and gaseous media



General



Features & benefits

- ▶ Stainless steel
- ▶ High leak tightness
- ▶ Valve seals are protected from media flow
- ▶ Wear and corrosion resistant
- ▶ Low-noise opening and closing
- ▶ Low cracking pressure
- ▶ Max. operating pressure up to 250 bar

Description

The WEH® TVR2 Check valves made of stainless steel are ideal for applications with liquid and gaseous media up to max. 250 bar. The possible applications are just as varied as the design and the materials used.

The check valves are available in various connection configurations, such as double ferrule fittings, female and male threads and a nominal bore of up to 20 mm. For smaller nominal bores the WEH® TVR200 Check valve is available.

Due to the high quality materials they are extremely wear-resistant, corrosion-resistant and durable. The check valves, which are very silent in use even under high flow rates, are characterized in particular by their very low cracking pressure and their optimum tightness.

The WEH® TVR2 are equipped with a cone seal. The internal seals are arranged so that they are protected from the media flow. This prevents damage to the seals from any dirt particles on the sealing components within the unit.

WEH® TVR2 Check valves are equipped with a FKM seal as standard. Other sealing materials are available on request. It is the customer's responsibility to clarify the media compatibility.

Intended use

The WEH® TVR2 Check valves were only developed for reliable return flow prevention in a gaseous or liquid media flow. They are not designed to be used as filling or safety valves. The separation or shut off between different media or a medium and vacuum also does not represent a fundamental intended use. If you have such an application or a similar application, please contact us!

The WEH® TVR2 Check valves are used in mechanical and plant engineering, chemical / pharmaceutical industry, conveyor technology, food industry, medical technology, etc.

General

Sealing concept

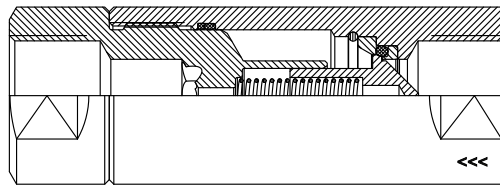

Cone seal construction

Flow values

In the table below you will find the flow rates of the various nominal bores of our WEH® TVR2 Stainless steel check valves.

Nominal bore (DN)	Kv (Cv) value	Nominal bore (DN)	Kv (Cv) value
10 mm	3.0 (3.4)	16 mm	8.1 (9.4)
14 mm	7.4 (8.6)	20 mm	10.7 (12.4)

The flow curves were determined on the basis of the DIN/EN 60534-2 standard and refer to a cavitation-free flow (water). System-sided constrictions at the inlet and outlet can reduce the flow rate.

Overview product series

Product series	Pressure range	Housing material	Connection types	Page
TVR2-S1	0 - 250 bar	Stainless steel	Double ferrule fitting Female thread Male thread	4

Overview product series & connection configurations

Product series	Media inlet B1	Media outlet B2	Page
TVR2-S1-A01	Double ferrule fitting	Double ferrule fitting	6
TVR2-S1-A02	Female thread	Female thread	7
TVR2-S1-A03	Male thread	Male thread	8
TVR2-S1-A10	Double ferrule fitting	Female thread	9
TVR2-S1-A11	Double ferrule fitting	Male thread	9
TVR2-S1-A12	Female thread	Double ferrule fitting	9
TVR2-S1-A13	Female thread	Male thread	9
TVR2-S1-A14	Male thread	Double ferrule fitting	9
TVR2-S1-A15	Male thread	Female thread	9

Technical data

Technical data | TVR2-S1

The following illustrations are examples of WEH® Check valves of the TVR2 product family.



Characteristics	Preferred variant space	Extended variant space
Product series	TVR2-S1	TVR2-S1
Connection configuration	A01, A02, A03	A01, A02, A03, A10, A11, A12, A13, A14, A15
Connection sizes for media inlet B1 / media outlet B2	<ul style="list-style-type: none"> • Tube Ø 12 mm, Ø 16 mm • G3/8", G1/2", G3/4", G1" 	On request
Nominal bore (DN)	Acc. to design	Acc. to design
Max. allowable operating pressure PS	250 bar	250 bar
Cracking pressure PC*	Acc. to design	Other cracking pressures on request
Temperature range	-20 °C up to +200 °C	Depending on sealing material
Leak rate	1 x 10 ⁻⁴ mbar x l/s	1 x 10 ⁻⁴ mbar x l/s
Housing material	Stainless steel	Stainless steel
Spring material	Stainless steel	Stainless steel
Sealing material DW	FKM	<ul style="list-style-type: none"> • FKM • Other sealing materials on request
Lubricant	Krytox® GPL 202	Krytox® GPL 202
Sealing concept	Cone sealing	Cone sealing
Flow direction	B1 → B2	B1 → B2

* Please note that the cracking pressures may differ due to tolerances. The cracking pressure basically applies to the horizontal mounting of the check valve. For other mounting directions, the values can differ.

Other designs on request

Technical data

Possible connection configurations

In addition to the table of technical characteristics (see page 4), the following possible connection configurations of WEH® Check valves of the TVR2 product family are listed. The connection configuration is part of the product series.

Connection configuration	Media inlet B1	Media outlet B2
A01	Double ferrule fitting	Double ferrule fitting
A02	Female thread	Female thread
A03	Male thread	Male thread
A10	Double ferrule fitting	Female thread
A11	Double ferrule fitting	Male thread
A12	Female thread	Double ferrule fitting
A13	Female thread	Male thread
A14	Male thread	Double ferrule fitting
A15	Male thread	Female thread

Ordering

Ordering | TVR2-S1-A01 - double ferrule fitting on both sides

Inlet B1: double ferrule fitting / outlet B2: double ferrule fitting

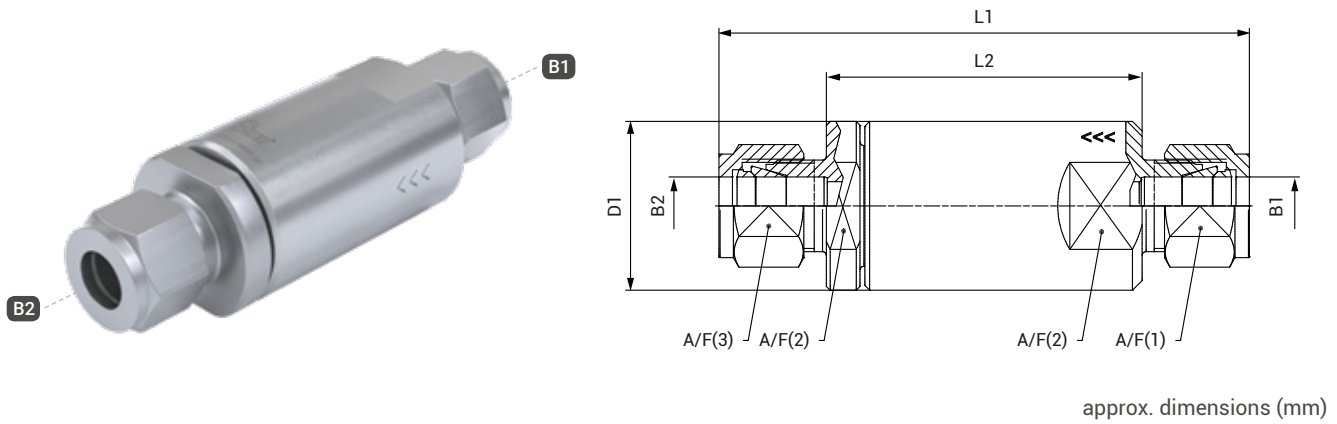

B1 / B2: Double ferrule fitting

Connection size: media inlet B1 = media outlet B2

Check valves of the preferred variant space:

Part No.	B1	B2	DN	PC (bar)	DW	L1	L2	D1	A/F(1) / A/F(3)	A/F(2)	AVL*
C1-171809	Ø 12	Ø 12	10	0.5	FKM	110	65.5	35	22	30	**
C20015-X1-X01	Ø 16	Ø 16	14	0.5	FKM	110	65.5	35	25	30	**

* AVL: availability see page 12 in catalog no. 45

** Availability on request

Ordering

Ordering | TVR2-S1-A02 - female thread on both sides

Inlet B1: female thread / outlet B2: female thread

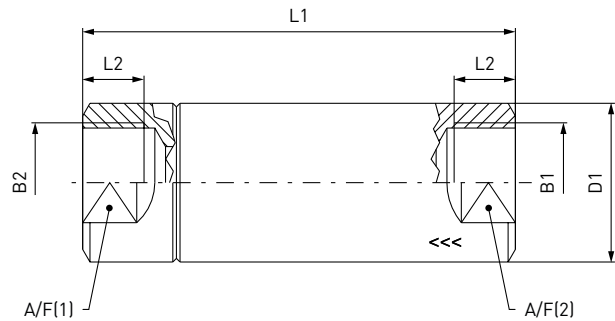

approx. dimensions (mm)

B1 / B2: Whitworth tube thread acc. to DIN EN ISO 228-1

Connection size: media inlet B1 = media outlet B2

Check valves of the preferred variant space:

Part No.	B1	B2	DN	PC (bar)	DW	L1	L2	D1	A/F(1) / A/F(2)	AVL*
C20002-X2-X01	G3/8"	G3/8"	14	0.1	FKM	95	17	35	30	RM
C20003-X2-X01	G1/2"	G1/2"	14	0.5	FKM	95	17	35	30	RM
C20004-X2-X01	G3/4"	G3/4"	16	0.5	FKM	110	17	39	34	RM
C20005/1-X01	G1"	G1"	20	1.0	FKM	120	18	48	41	RM

* AVL: availability see page 12 in catalog no. 45

Ordering

Ordering | TVR2-S1-A03 - male thread on both sides

Inlet B1: male thread / outlet B2: male thread

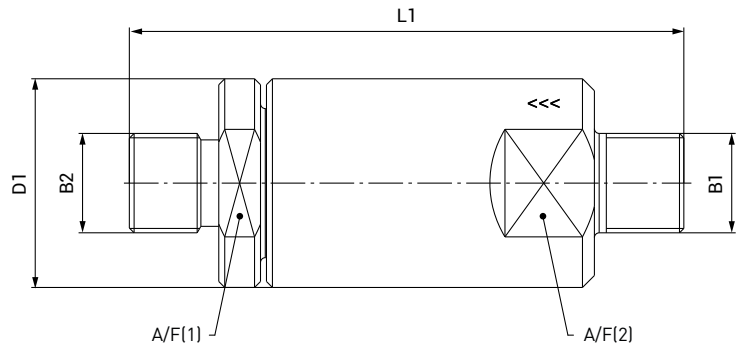

approx. dimensions (mm)

B1 / B2: Whitworth tube thread acc. to DIN EN ISO 228-1

Connection size: media inlet B1 = media outlet B2

Check valves of the preferred variant space:

Part No.	B1	B2	DN	PC (bar)	DW	L1	D1	A/F(1) / A/F(2)	AVL*
C20203	G3/8"	G3/8"	10	0.1	FKM	93	35	30	**
C20204-X01	G1/2"	G1/2"	14	0.5	FKM	95	35	30	RM
C20205-X01	G3/4"	G3/4"	16	0.5	FKM	110	39	34	**
C20206	G1"	G1"	20	1.0	FKM	124	48	41	**

* AVL: availability see page 12 in catalog no. 45

** Availability on request

Ordering

Ordering | Extended variant space

Configurable check valves of the extended variant space.

Check valves of the extended variant space offer further configuration options beyond the preferred variant space.

The following characteristics are configurable:

- Connection configurations
- Connection sizes for media ports (B1 / B2)
- Cracking pressure
- Sealing material

For this, please select the technical characteristics from the table below and request your WEH® TVR2 Check valve. The following illustrations are examples of WEH® Check valves of the TVR2 product family.



Further designs that do not correspond to the extended variant space can be requested individually. Please refer to *chapter 1.9 Information on your request* in catalog no. 45. Please note that the availability for individual, customer-specific check valves may vary.

Technical data

Characteristics	Extended variant space
Product series	TVR2-S1
Connection configuration	A01, A02, A03, A10, A11, A12, A13, A14, A15
Connection sizes for media inlet B1 / media outlet B2	<ul style="list-style-type: none"> • Tube Ø 12 mm, Ø 16 mm • G3/8", G1/2", G3/4", G1"
Nominal bore (DN)	Acc. to design
Max. allowable operating pressure PS	250 bar
Cracking pressure PC*	On request
Temperature range	Depending on sealing material
Leak rate	1 x 10 ⁻⁴ mbar x l/s
Housing material	Stainless steel
Spring material	Stainless steel
Sealing material DW	On request
Lubricant	Krytox® GPL 202
Sealing concept	Ball sealing
Flow direction	B1 → B2

* Please note that the cracking pressures may differ due to tolerances. The cracking pressure basically applies to the horizontal mounting of the check valve. For other mounting directions, the values can differ.

Other designs on request

Ordering

Possible connection configurations

In addition to the table of technical characteristics (see page 9), the following possible connection configurations of WEH® Check valves of the TVR2 product family are listed. The connection configuration is part of the product series.

Connection configuration	Media inlet B1	Media outlet B2
A01	Double ferrule fitting	Double ferrule fitting
A02	Female thread	Female thread
A03	Male thread	Male thread
A10	Double ferrule fitting	Female thread
A11	Double ferrule fitting	Male thread
A12	Female thread	Double ferrule fitting
A13	Female thread	Male thread
A14	Male thread	Double ferrule fitting
A15	Male thread	Female thread

Further products

You will find more products in our current catalog no. 45.

Technical explanations

TECHNICAL EXPLANATIONS

Abbreviations/Definitions

For explanation of abbreviations and definitions of terms see technical appendix of the corresponding catalog or www.weh.com

Illustrations

The illustrations and/or images used in these data sheet are particularly provided for illustrative purposes only and may differ in some details from the actual product. For binding information, please refer to your individual orders.

Safe product selection

Our WEH® Products are designed to be operated by qualified professional users (insofar as WEH® Products are also designed to be operated by other users in individual cases, this is explicitly stated in the corresponding operating instructions). Please note that WEH does not know your system and therefore - also due to the large number of different potential applications of WEH® Products - cannot perform tests on all potential types of application. You alone are responsible for the selection, configuration and suitability of WEH® Products, especially according to the requirements of your system. Before purchasing WEH® Products, please particularly ensure that our products are compatible with your intended use, your performance data, your material and fluids, your system concept and your system limits according to our product specifications. Please also consider your technical and legal requirements for operation, handling and maintenance. The quality and safety of WEH® Products is our highest priority. For this reason, WEH® Products may not be used outside the specifications in the relevant data sheets and product descriptions. If you are not sure whether the WEH® Product is suitable for your system and intended use, please contact us in advance. We also strongly recommend that you refrain from using third-party spare parts or a combination of WEH® Products with unsuitable third-party products. You alone are responsible for reviewing the suitability of third-party products. WEH® Products and WEH® Spare parts comply with our quality and safety standards.

Service life

WEH® Products are generally products which may be subject to wear and fatigue during operation and depending on your individual application/use. For details - in particular regarding the corresponding minimum inspection and maintenance intervals - please refer to the respective operating instructions for the WEH® Product.

Explanation on the Pressure Equipment Directive

These WEH® Products are generally classified as pressure accessories in accordance with Article 2 (5) of the Pressure Equipment Directive 2014/68/EU and are considered to be similar to piping. These WEH® Products may not be used as safety accessories. Furthermore, it is pointed out, that these WEH® Products are designed and placed on the market in accordance with the requirements of Article 4 (3) of the Pressure Equipment Directive 2014/68/EU. The assessment with regard to a different classification can, however, be made on request.

External change management

WEH reserves the right to update, optimise and adjust its products continuously. This may result in corresponding changes of the product. Customers will be informed proactively or unsolicited by WEH only in individual cases about product updates, product optimisations and/or product adaptations that have been carried out. You are free to contact WEH at any time to request information about any product updates, product optimisations and/or product adjustments.

© All rights reserved, WEH GmbH. Any unauthorized use is strictly forbidden. Subject to alteration.
No liability will be assumed for any content. Herewith previous versions are no longer valid.

» Contact

More questions? – Great! Don't hesitate to contact our experts.

Manufacturer:

WEH GmbH Precision Connectors

Josef-Henle-Str. 1
89257 Illertissen / Germany

Phone: +49 7303 9609-0

E-Mail: sales@weh.com

Website: www.weh.com