

SCREW-IN VALVES FOR GENERAL APPLICATIONS

# TVR400 of stainless steel

for hydraulic and pneumatic applications



## General



### Features & benefits

- ▶ Soft-sealing → high leak tightness, low leakage
- ▶ Compact and space-saving
- ▶ Flow in screwing direction
- ▶ Use at high temperatures and pressure peaks up to 250 bar
- ▶ High flow rate
- ▶ Easy installation

## Description

The WEH® TVR400 Screw-in valves are mechanical shut-off valves which allow free media flow in the screwing direction of screw rotation and which shut off the media flow in the other direction.

Their compact design means that they have a small footprint and are therefore very economical. Unlike valve concepts with metallic sealing, the TVR400 screw-in valves are soft-sealing. Sealing is provided by a spring-loaded sealing cone with o-ring. Therefore, the WEH® Valves are characterized by a high leak tightness, combined with a high flow rate.

The WEH® Screw-in valves can be easily screwed into internally threaded bores using an Allen key. TVR400 valves are made of high quality stainless steel and are therefore very durable and wear-resistant. They are especially low-noise in operation.

WEH® TVR400 Screw-in valves are equipped with a FKM seal as standard. Other sealing materials are available on request. It is the customer's responsibility to clarify the media compatibility.

## Intended use

The WEH® TVR400 Screw-in valves were only developed for reliable return flow prevention in a gaseous or liquid media flow. They are not designed to be used as filling or safety valves. The separation or shut off between different media or a medium and vacuum also does not represent a fundamental intended use.

If you have such an application or a similar application, please contact us!

The WEH® TVR400 Check valves are suitable for hydraulic and pneumatic applications in mechanical and plant engineering, conveyor technology and medical technology as well as in the chemical and pharmaceutical industry.

General

## Sealing concept

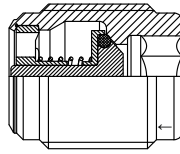

Cone seal construction

## Flow values

In the table below you will find the flow rates of the various nominal bores of our WEH® TVR400 Stainless steel screw-in valves.

Nominal bore (DN)	Kv (Cv) value	Nominal bore (DN)	Kv (Cv) value	Nominal bore (DN)	Kv (Cv) value
3.6 mm	0.286 (0.331)	6 mm	0.640 (0.743)	7 mm	1.203 (1.395)

The flow curves were determined on the basis of the DIN/EN 60534-2 standard and refer to a cavitation-free flow (water). System-sided constrictions at the inlet and outlet can reduce the flow rate.

## Overview product series

Product series	Pressure range	Housing material	Connection types	Page
TVR400-S1	0 - 250 bar	Stainless steel	Male thread	4

## Overview product series & connection configurations

Product series	Media inlet B1	Page
TVR400-S1-A20	Male thread	5

Technical data

**Technical data | TVR400-S1**

The following illustrations are examples of WEH® Check valves of the TVR400 product family.



Characteristics	Preferred variant space	Extended variant space
Product series	TVR400-S1	TVR400-S1
Connection configuration	A20	A20
Connection sizes for media inlet B1	<ul style="list-style-type: none"> <li>• G1/8", G1/4", G3/8"</li> <li>• M10x1.0 M14x1.5 M18x1.5</li> </ul>	<ul style="list-style-type: none"> <li>• G1/8", G1/4", G3/8"</li> <li>• M10x1.0 M14x1.5 M18x1.5</li> </ul>
Nominal bore (DN)	Acc. to design	Acc. to design
Max. allowable operating pressure PS	250 bar	250 bar
Cracking pressure PC	<b>0.5 ± 0.2 bar</b>	<b>Other cracking pressures on request</b>
Temperature range	-20 °C up to +200 °C	Depending on sealing material
Leak rate	1 x 10 <sup>-3</sup> mbar x l/s	1 x 10 <sup>-3</sup> mbar x l/s
Housing material	Stainless steel	Stainless steel
Spring material	Stainless steel	Stainless steel
Sealing material DW	<b>FKM</b>	<ul style="list-style-type: none"> <li>• <b>FKM</b></li> <li>• <b>EPDM</b></li> </ul>
Sealing concept	Cone sealing (with internal o-ring)	Cone sealing (with internal o-ring)
Flow direction	In screwing direction	In screwing direction

Other designs on request

**Possible connection configurations**

In addition to the table of technical characteristics (see above), the following possible connection configurations of WEH® Check valves of the TVR400 product family are listed. The connection configuration is part of the product series.

Connection configuration	Media inlet B1
A20	Male thread

Ordering

Ordering | TVR400-S1-A20 - male thread

Inlet B1: male thread

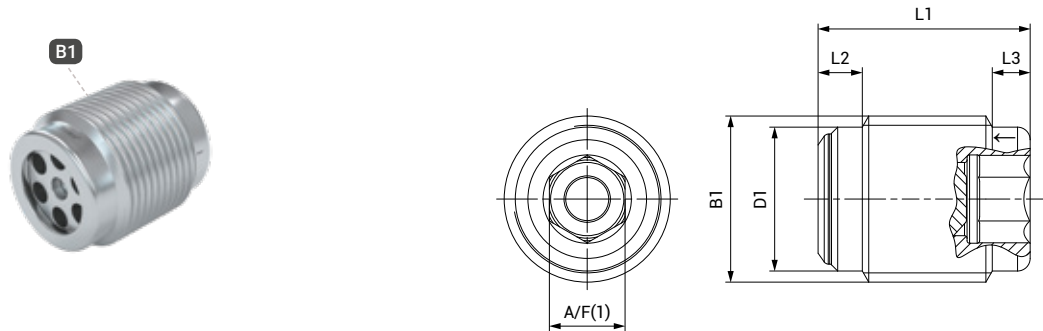

approx. dimensions (mm)

**B1 / B2: Whitworth tube thread acc. to DIN EN ISO 228-1**

Check valves of the preferred variant space:

Part No.	B1	DN	PC (bar)	DW	L1	L2	L3	D1	A/F(1)	AVL*
C1-109260	G1/8"	3.6	0.5 ± 0.2	FKM	15.5	3	2	8.5	5	RM
C1-136902	G1/4"	6	0.5 ± 0.2	FKM	17	3.5	3	11.5	6	RM
C1-109268	G3/8"	7	0.5 ± 0.2	FKM	20	3.5	3	14.5	8	RM

\* AVL: availability see page 12 in catalog no. 45

**B1: Metric ISO thread acc. to DIN 13**

Check valves of the preferred variant space:

Part No.	B1	DN	PC (bar)	DW	L1	L2	L3	D1	A/F(1)	AVL*
C1-109280	M10x1.0	3.6	0.5 ± 0.2	FKM	15.5	3	2	8.5	5	RM
C1-109284	M14x1.5	6	0.5 ± 0.2	FKM	17	3.5	3	11.5	6	RM
C1-109288	M18x1.5	7	0.5 ± 0.2	FKM	20	3.5	3	14.5	8	RM

\* AVL: availability see page 12 in catalog no. 45

**Configurable check valves of the extended variant space:**

Below you will find possible examples of TVR400 check valves in the extended variant space. This offers further configuration options (connection configuration, connection size, cracking pressure, sealing material) beyond the preferred variant space.

Part No.	B1	DN	PC (bar)	DW	L1	L2	L3	D1	A/F(1)	AVL*
On request	G1/8"	3.6	0.5 ± 0.2	EPDM					On request	AH
On request	G3/8"	7	0.2	EPDM					On request	AH
On request	M14x1.5	6	0.1	FKM					On request	AH

\* AVL: availability see page 12 in catalog no. 45

Further designs that do not correspond to the extended variant space can be requested individually.

Please refer to chapter 1.9 Information on your request in catalog no. 45.

Please note that the availability for individual, customer-specific check valves may vary.

Ordering

## Further products

---

You will find more products in our current catalog no. 45.

## Technical explanations

### TECHNICAL EXPLANATIONS

#### Abbreviations/Definitions

For explanation of abbreviations and definitions of terms see technical appendix of the corresponding catalog or [www.weh.com](http://www.weh.com)

#### Illustrations

The illustrations and/or images used in these data sheet are particularly provided for illustrative purposes only and may differ in some details from the actual product. For binding information, please refer to your individual orders.

#### Safe product selection

Our WEH® Products are designed to be operated by qualified professional users (insofar as WEH® Products are also designed to be operated by other users in individual cases, this is explicitly stated in the corresponding operating instructions). Please note that WEH does not know your system and therefore - also due to the large number of different potential applications of WEH® Products - cannot perform tests on all potential types of application. You alone are responsible for the selection, configuration and suitability of WEH® Products, especially according to the requirements of your system. Before purchasing WEH® Products, please particularly ensure that our products are compatible with your intended use, your performance data, your material and fluids, your system concept and your system limits according to our product specifications. Please also consider your technical and legal requirements for operation, handling and maintenance. The quality and safety of WEH® Products is our highest priority. For this reason, WEH® Products may not be used outside the specifications in the relevant data sheets and product descriptions. If you are not sure whether the WEH® Product is suitable for your system and intended use, please contact us in advance. We also strongly recommend that you refrain from using third-party spare parts or a combination of WEH® Products with unsuitable third-party products. You alone are responsible for reviewing the suitability of third-party products. WEH® Products and WEH® Spare parts comply with our quality and safety standards.

#### Service life

WEH® Products are generally products which may be subject to wear and fatigue during operation and depending on your individual application/use. For details - in particular regarding the corresponding minimum inspection and maintenance intervals - please refer to the respective operating instructions for the WEH® Product.

#### Explanation on the Pressure Equipment Directive

These WEH® Products are generally classified as pressure accessories in accordance with Article 2 (5) of the Pressure Equipment Directive 2014/68/EU and are considered to be similar to piping. These WEH® Products may not be used as safety accessories. Furthermore, it is pointed out, that these WEH® Products are designed and placed on the market in accordance with the requirements of Article 4 (3) of the Pressure Equipment Directive 2014/68/EU. The assessment with regard to a different classification can, however, be made on request.

#### External change management

WEH reserves the right to update, optimise and adjust its products continuously. This may result in corresponding changes of the product. Customers will be informed proactively or unsolicited by WEH only in individual cases about product updates, product optimisations and/or product adaptations that have been carried out. You are free to contact WEH at any time to request information about any product updates, product optimisations and/or product adjustments.

© All rights reserved, WEH GmbH. Any unauthorized use is strictly forbidden. Subject to alteration.  
No liability will be assumed for any content. Herewith previous versions are no longer valid.

#### » Contact

More questions? – Great! Don't hesitate to contact our experts.

Manufacturer:

##### **WEH GmbH Precision Connectors**

Josef-Henle-Str. 1  
89257 Illertissen / Germany

Phone: +49 7303 9609-0

E-Mail: [sales@weh.com](mailto:sales@weh.com)

Website: [www.weh.com](http://www.weh.com)